

CANDIDATE
NAME

CENTRE
NUMBER

--	--	--	--	--

CANDIDATE
NUMBER

--	--	--	--

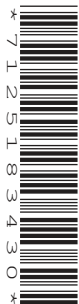

COMBINED SCIENCE

0653/33

Paper 3 (Core)

October/November 2018

1 hour 15 minutes

Candidates answer on the Question Paper.

No Additional Materials are required.

READ THESE INSTRUCTIONS FIRST

Write your Centre number, candidate number and name on all the work you hand in.

Write in dark blue or black pen.

You may use an HB pencil for any diagrams or graphs.

Do not use staples, paper clips, glue or correction fluid.

DO NOT WRITE IN ANY BARCODES.

Answer **all** questions.

Electronic calculators may be used.

You may lose marks if you do not show your working or if you do not use appropriate units.

A copy of the Periodic Table is printed on page 20.

At the end of the examination, fasten all your work securely together.

The number of marks is given in brackets [] at the end of each question or part question.

This document consists of **20** printed pages.

1 (a) Fig. 1.1 shows a flowering plant and some functions carried out by the plant.

Draw **one** straight line from each box to a part of the plant where the function is carried out. [4]

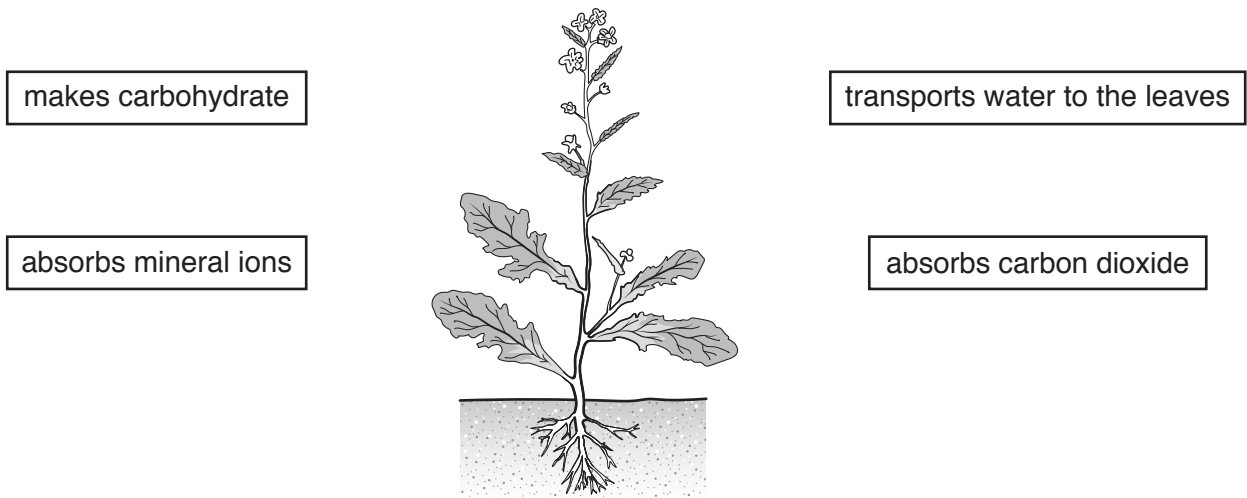

Fig. 1.1

(b) Fig. 1.2 shows a drawing of a vertical section through a flower.

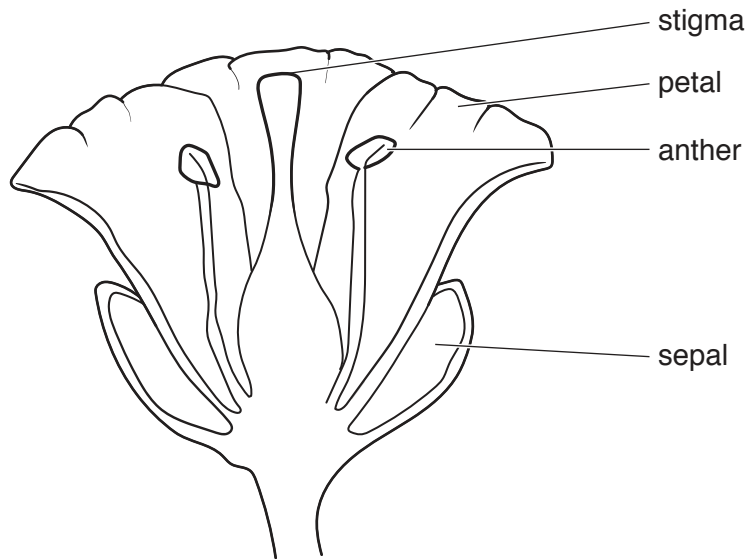

Fig. 1.2

Suggest **one** piece of evidence shown in Fig. 1.2 that the flower is insect pollinated.

.....
..... [1]

- (c) Fig. 1.3 shows a drawing of a pollen grain from an insect-pollinated flower, viewed using a microscope.

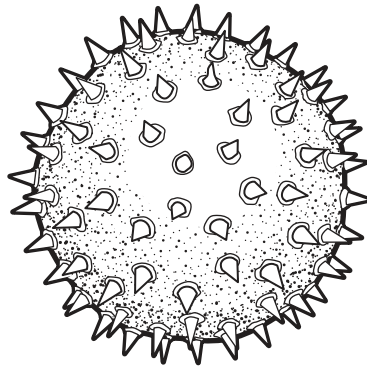

Fig. 1.3

Suggest **and** explain how the structure of the pollen grain makes it suitable for insect pollination.

.....
.....
.....[2]

- (d) (i) Oxygen is required for the germination of seeds.

Explain in detail why germination requires a supply of oxygen.

.....
.....
.....[2]

- (ii) State **one other** environmental condition that is needed for germination.

.....[1]

- 2 (a) The Periodic Table contains the symbols of all of the elements.

Complete the sentences about the Periodic Table.

The Periodic Table lists the elements in order of their number.

The unreactive gases in Group VIII, which include helium, neon and argon, are known as the gases.

The collection of metals in the middle of the Periodic Table have high densities and form coloured compounds. They are known as the elements.

[3]

- (b) Carbon dioxide is a compound of carbon and oxygen, two non-metallic elements.

(i) State the name of the type of bonding between a carbon atom and an oxygen atom.

.....[1]

(ii) Describe, in terms of electrons, the bonding between a carbon atom and an oxygen atom.

.....
[1]

- (c) The compound sodium chloride contains sodium ions and chloride ions.

Describe, in terms of electrons, the formation of ions from atoms.

.....
[1]

- (d) A mixture contains aqueous sodium chloride and insoluble powdered charcoal (carbon).

(i) Suggest how the powdered charcoal can be separated from the mixture.

.....
[1]

(ii) Suggest how water can be removed from aqueous sodium chloride.

.....
[1]

- (iii) State whether the separation of this mixture into charcoal, water and sodium chloride is a physical change or a chemical change.

Explain your answer.

change

explanation

.....

[1]

3 Fig. 3.1 shows a man pushing a shopping trolley.



Fig. 3.1

(a) The man and the trolley are moving. Fig. 3.2 shows the four forces **W**, **X**, **Y** and **Z** acting on the trolley.

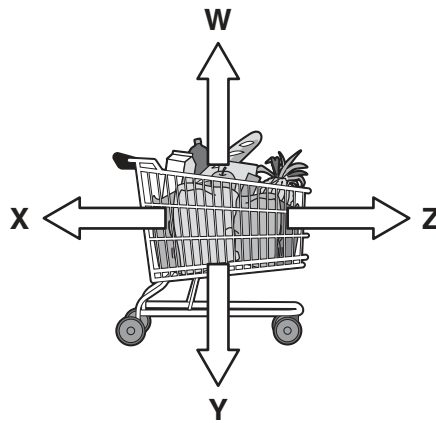

Fig. 3.2

State the letter corresponding to the gravitational force acting on the trolley.

.....

[1]

(b) Fig. 3.3 shows a speed–time graph of the trolley as the man pushes it to the checkout.

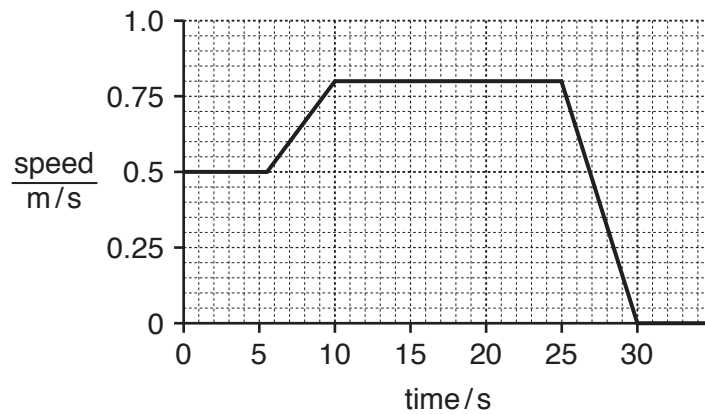

Fig. 3.3

(i) On Fig. 3.3, label with a letter **C** a point in the journey when the trolley is travelling with changing speed. [1]

(ii) The trolley travels 20m to the checkout.

Use information from the graph to calculate the average speed of the trolley on this journey.

Show your working.

average speed = m/s [2]

(c) The man provides the energy to push the trolley to the checkout. The original source of the energy in the man is the Sun.

(i) Use words from the list to complete the sentences that describe how energy is transferred from the Sun to move the trolley.

Each word may be used once, more than once, or not at all.

chemical electrical gravitational kinetic nuclear

Light energy from the Sun is converted to energy in food.

When the man eats the food, he gains energy.

When he pushes the trolley, some of this energy is transferred to the energy of the trolley. [3]

(ii) To keep the trolley moving at constant speed for 15s, an energy input of 20000J to the man is needed. Only 2400J is required to do the work against forces resisting the motion.

Describe what happens to most of the wasted energy.

.....
.....[1]

4 (a) Fig. 4.1 shows a diagram of part of the alimentary canal and its associated organs.

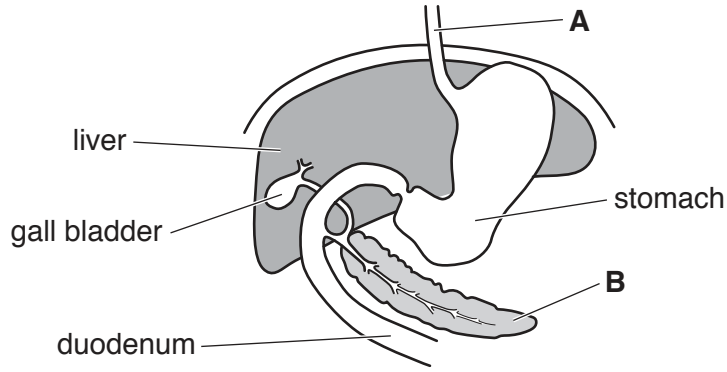

Fig. 4.1

(i) Name structures **A** and **B** shown on Fig. 4.1.

A

B

[2]

(ii) During digestion food passes through the duodenum.

State where the food goes to immediately after passing through the duodenum.

.....[1]

(iii) Describe the function of the gall bladder.

.....[1]

(b) Table 4.1 shows the approximate pH values in some areas of the alimentary canal.

Table 4.1

area of alimentary canal	approximate pH in area
mouth cavity	7
stomach	2
duodenum	8

Enzymes in the mouth begin the digestion of starch in food.

Suggest why more enzymes must be secreted into the small intestine to complete the digestion of starch.

.....

[2]

(c) Glucose is transported to the body cells in the blood plasma.

List **two** other soluble substances which are transported by the plasma.

1.

2.

[2]

(d) Describe how oxygen is transported in the blood around the body.

.....

.....

..... [2]

- 5 (a) A student investigates the rate of reaction of four metals, calcium, iron, magnesium and zinc, with dilute hydrochloric acid.

She uses pieces of metal which are all of the same size.

A gas is produced when the metals react.

She uses the apparatus shown in Fig. 5.1.

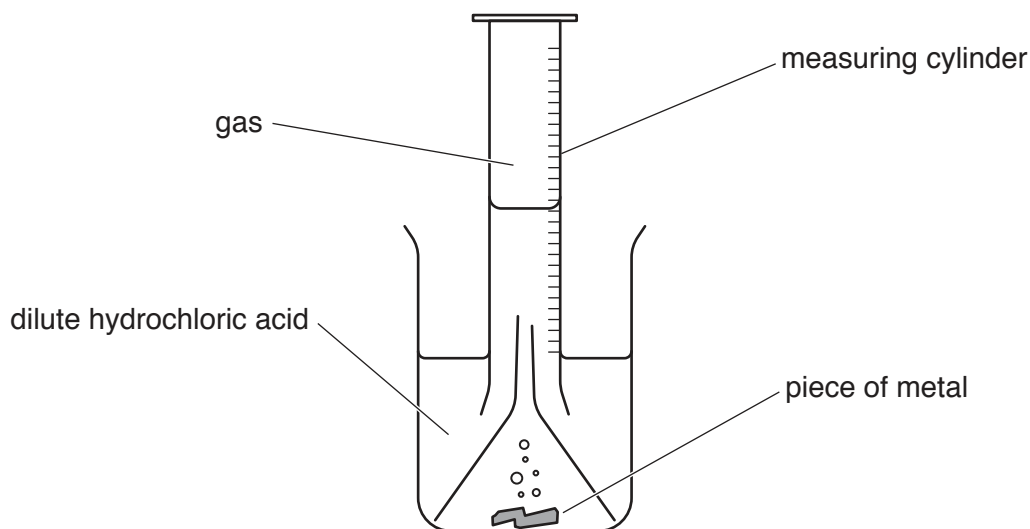

Fig. 5.1

The student determines the rate of the reaction between each metal and the dilute acid.

- (i) Describe the **two** measurements that the student records for each reaction.

1.

2.

[2]

- (ii) Place calcium, iron, magnesium and zinc, in order of rate of reaction, from highest to lowest.

..... highest

 lowest

[1]

- (iii) During the reaction between magnesium and dilute hydrochloric acid, hydrogen gas and a salt are produced.

Complete the word equation for this reaction.

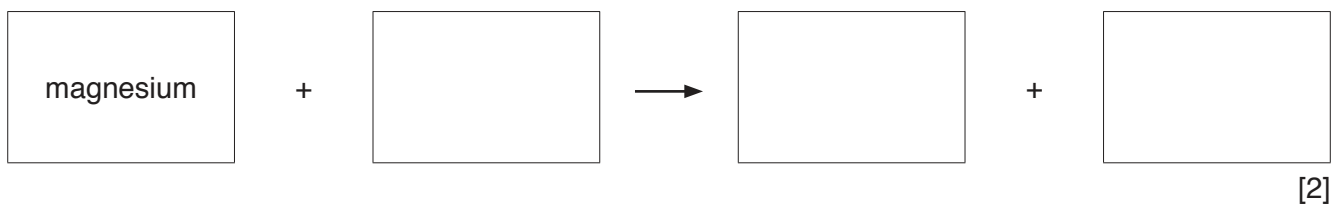

- (iv) Describe a test for hydrogen gas.

State the test result.

test

result

.....

[2]

- (b) Copper is a metal which is extracted by heating copper oxide with carbon.

The equation for this reaction is:



Name the substance that is oxidised during this reaction.

Explain your answer.

substance

explanation

.....

[1]

6 (a) (i) State **one** property that distinguishes a liquid from a gas.

.....[1]

(ii) Describe how this property is the result of a difference in the arrangement of molecules.

.....
[2]

(b) When gases are heated, they expand.

Describe **one** example of a use of this property of gases.

.....
[1]

(c) Fig. 6.1 shows a pan of boiling water left to cool on a balance.

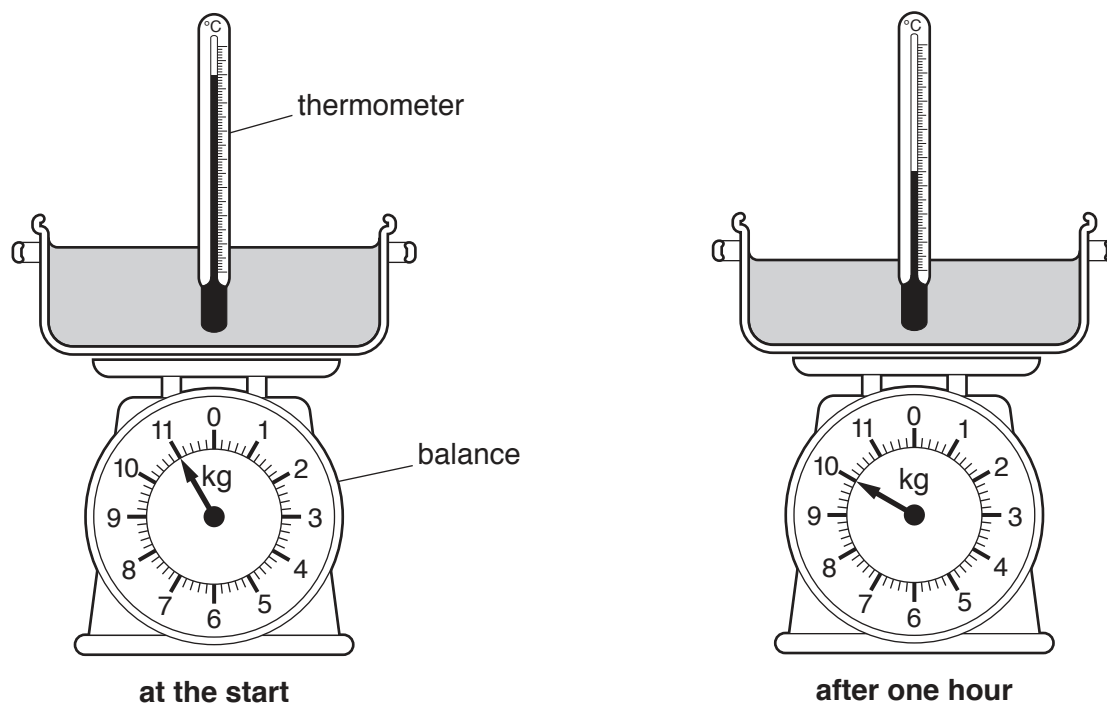

Fig. 6.1

After one hour, the reading on the scale of the balance has changed.

(i) Name the process that has caused the change in the mass of water in the pan.

.....[1]

- (ii) The thermometer in Fig. 6.1 shows that the temperature of the water and the pan is less after one hour.

State the main method of heat loss

1. from the inside to the outside of the pan,

.....

2. from the outside of the pan to the room.

.....

[2]

- (d) An observer is measuring the temperature of the water in the pan in (c).

He says the thermometer looks bent where it goes into the water. He says the thermometer bulb is at X on Fig. 6.2.

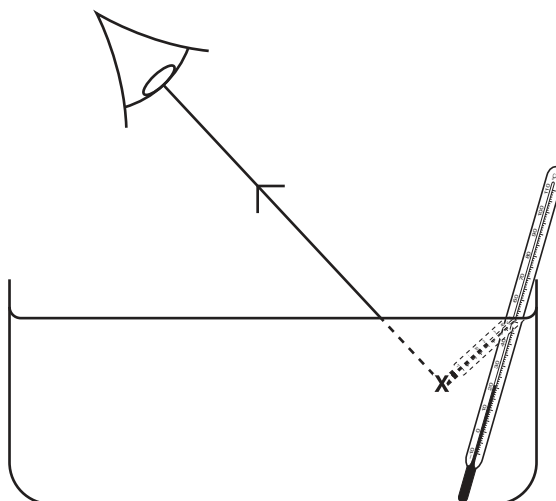

Fig. 6.2

- (i) Rays of light change direction when they pass through the surface of the water.

Name this effect.

..... [1]

- (ii) Fig. 6.2 shows where the observer thinks the ray is coming from.

On Fig. 6.2 complete the ray diagram to show where the ray is actually coming from. [1]

- 7 Rainforest is often cleared for agriculture. Trees are cut down and burned to prepare the land for planting crops. This practice is called 'slash and burn'.

The burning of the trees produces carbon dioxide gas and a smoky haze made from very small carbon particles suspended in the air.

Fig. 7.1 is a picture of clearing land by slash and burn.

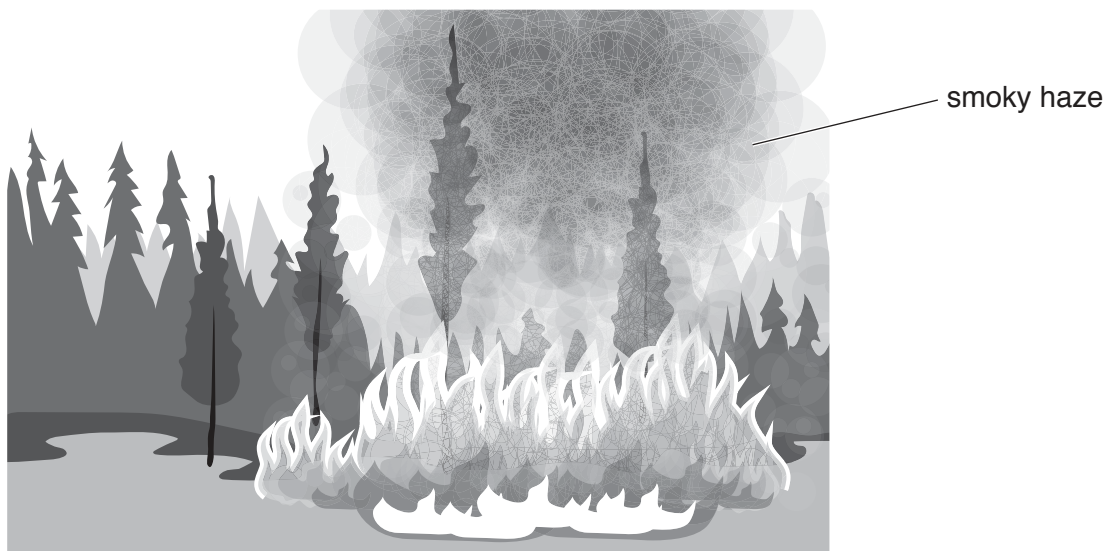

Fig. 7.1

- (a) The wind carries the smoky haze to neighbouring countries.

Suggest **and** explain how the smoky haze affects the rate of photosynthesis in plants in these countries.

.....
 [1]

- (b) After slash and burn there is an increased risk of loss of soil from the area.

Suggest a reason for this loss of soil from the area.

Explain your answer.

reason

.....

explanation

.....

[2]

(c) State **two** effects of slash and burn on the animals living in the trees.

1.

2.

[2]

(d) The practice of slash and burn causes the concentration of carbon dioxide in the atmosphere to increase.

Explain why this is undesirable for the environment.

.....

.....

..... [2]

- 8 (a) Petroleum is separated into useful fractions, as shown in Fig. 8.1.

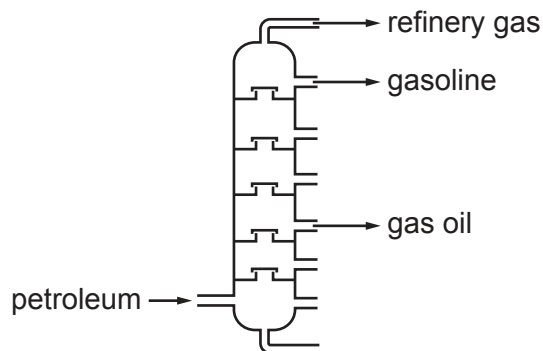

Fig. 8.1

- (i) Petroleum is a fossil fuel.

Name two other fossil fuels.

1.
2.

[1]

- (ii) The fractions obtained from petroleum have different uses as fuels.

Draw **one** line from each use to the fraction from which the fuel is obtained.

One line has been drawn for you.

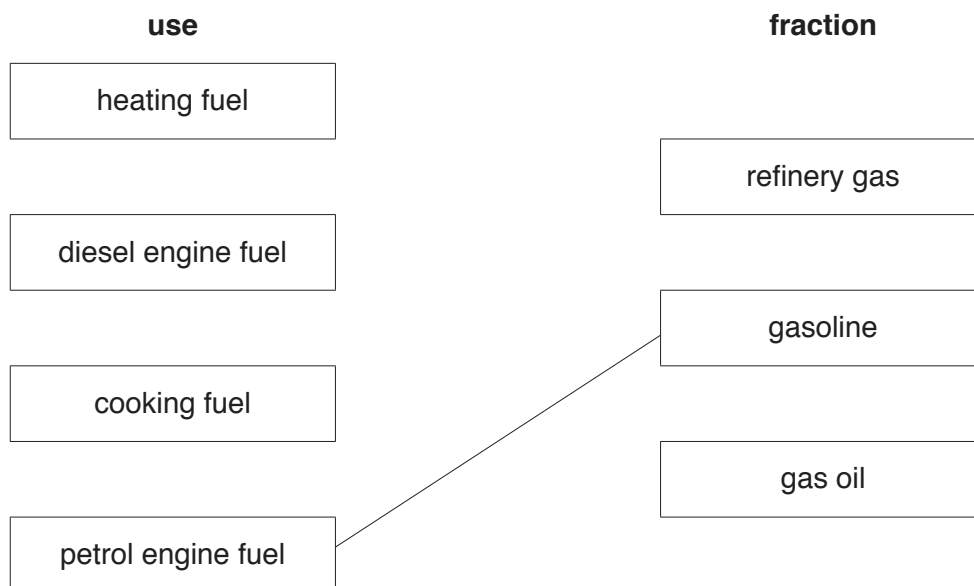

[2]

- (iii) When fuels burn, the reaction produces a temperature increase.

State the name given to reactions that always cause a temperature increase.

.....[1]

- (b) (i) The structure of a molecule of a compound is shown below.

Name this compound.

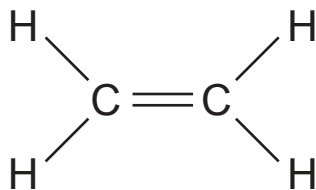

.....[1]

- (ii) The formula of ethanol is $\text{C}_2\text{H}_5\text{OH}$.

Complete the structure of a molecule of ethanol.



[2]

- (c) Petroleum is a mixture of different compounds.

Methane, CH_4 , is a compound.

- (i) State what is meant by a *compound*.

Use ideas about atoms in your answer.

.....
[1]

- (ii) Explain what is meant by a *mixture*.

You may use ideas about separation methods in your answer.

.....
[1]

9 Fig. 9.1 shows a display refrigerator for storing cold drinks.

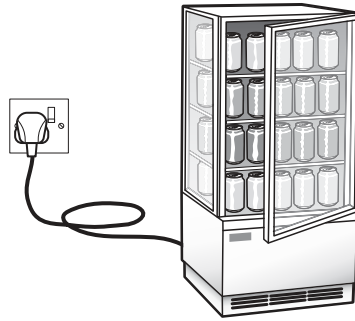

Fig. 9.1

The refrigerator uses electrical energy

- for a lamp to light up the inside of the refrigerator
- to power an electric motor to run the cooler in the refrigerator.

The circuit symbol for an electric motor is:



Fig. 9.2 shows part of the circuit diagram for the refrigerator.

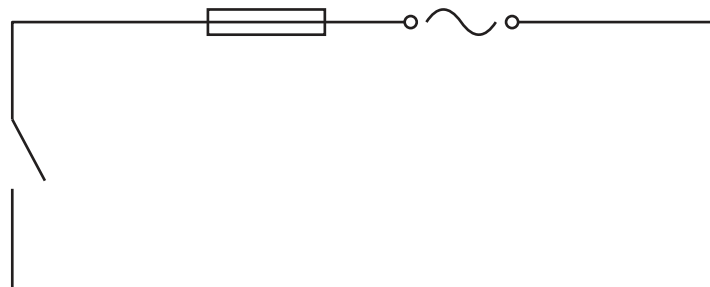

Fig. 9.2

(a) (i) The electric motor and lamp are connected in parallel.

The lamp has a switch in series so it can be switched off while the motor is switched on.

On Fig. 9.2 complete the circuit diagram for the refrigerator.

[4]

(ii) Suggest why it is an advantage to have the electric motor and lamp connected in parallel.

..... [1]

(iii) Name the circuit component with the symbol 

..... [1]

(iv) State why a fuse has been included in the circuit.

.....
..... [1]

(b) The potential difference across the electric motor is 240 V. When the electric motor is working, a current of 1.25 A flows through it.

Calculate the resistance of the electric motor.

State the formula you use, show your working and give the unit of your answer.

formula

working

resistance = unit [3]

Permission to reproduce items where third-party owned material protected by copyright is included has been sought and cleared where possible. Every reasonable effort has been made by the publisher (UCLES) to trace copyright holders, but if any items requiring clearance have unwittingly been included, the publisher will be pleased to make amends at the earliest possible opportunity.

To avoid the issue of disclosure of answer-related information to candidates, all copyright acknowledgements are reproduced online in the Cambridge International Examinations Copyright Acknowledgements Booklet. This is produced for each series of examinations and is freely available to download at www.cie.org.uk after the live examination series.

Cambridge International Examinations is part of the Cambridge Assessment Group. Cambridge Assessment is the brand name of University of Cambridge Local Examinations Syndicate (UCLES), which is itself a department of the University of Cambridge.

